



XBC 75 & 85

Ecosmart Classic (ES) / Basic (BC) Control
Supply & Extract Ventilation with Heat Recovery
Installation Manual



1.0 SAFETY INFORMATION

- The provision of the electrical supply and the connection of the unit to the electrical supply must be carried out by a qualified electrician.
- Isolate from power supply before removing any covers. During installation / maintenance ensure all covers are fitted before switching on the mains supply.
- All-pole disconnection from the mains as shown in the wiring diagram must be incorporated within the fixed wiring and shall have a minimum contact separation of 3mm in accordance with latest edition of the wiring regulations.
- This unit must be earthed.
- Ducting must be securely fixed with screws to the spigot to prevent access to live parts. Duct runs terminating close to the fan must be adequately protected by suitable guards.
- This appliance should not be used by children or persons with reduced physical, sensory or mental capabilities or lack of experience and knowledge, unless they have been given supervision or instruction concerning the safe use of the appliance by a person responsible for their safety. Children shall not play with the appliance. Cleaning and user maintenance shall not be carried out by children.

1.1 Symbols



GENERAL WARNING

Signifies a general warning regarding hazard specified by supplementary information.



ELECTRIC SHOCK

This unit must be completely electrically isolated before any panels are removed. Check mains supply and control connections.



ROTATING PARTS

This unit contains fast moving rotational parts which may start automatically. It is the sole responsibility of the installer to adequately guard these components.



REFER TO INSTRUCTION MANUAL

Read and understand the installation and maintenance manual before installing, operating or maintaining this product.

1.2 Important Information

This manual contains important information on the safe and appropriate assembly, transport, commissioning, operation, maintenance, disassembly and simple troubleshooting of the product.

While the product has been manufactured according to the accepted rules of current technology, there is still a danger of personal injury or damage to equipment if the following general safety instructions and the warnings contained in these instructions are not complied with.

- **Read these instructions completely and thoroughly before working with the product.**
- **Keep these instructions in a location where they are accessible to all users at all times.**
- **Always include the operating instructions when you pass the product on to third parties.**

1.3 Personal Protective Equipment

The following minimum Personal Protective Equipment (PPE) is recommended when interacting with Nuairé product:

- **Protective Steel Toed Shoes** - when handling heavy objects.
- **Full Finger Gloves (Marigold PU800 or equivalent)** - when handling sheet metal components.
- **Semi Fingerless Gloves (Marigold PU3000 3DO or equivalent)** - when conducting light work on the unit requiring tactile dexterity.
- **Safety Glasses** - when conducting any cleaning/cutting operation or exchanging filters.
- **Reusable Half Mask Respirators** - when replacing filters which have been in contact with normal room or environmental air.

Nuairé would always recommend a site specific risk assessment by a competent person to determine if any additional PPE is required.

2.0 INTRODUCTION

The information contained in this document provides details of installation, operation and maintenance for installers and users of the XBOXER XBC75 & 85 Supply and Extract Ventilation Units with Heat Recovery.

This supply and extract air handling unit range comprises an combination of high efficiency centrifugal fans with EC motors, a counterflow design plate heat exchanger, filters, optional heaters (LPHW and Electric) and a casing with high mass acoustic treatment.

The one-piece ventilation unit shall be constructed with double skinned Aluzinc panels on an aluminium Pentapost frame with integral acoustic mineral fibre ensuring low breakout noise levels. The unit shall incorporate a high efficiency aluminium counterflow plate heat exchanger matrix with a thermal efficiency of up to 92%, fitted with a segmented 100% bypass facility and actuator (patent app. for) operating under automatic control.

A range of matched, side by side internal and external attenuators (Horizontal units) and double deck internal and external attenuators (Vertical units) with a similar construction method to that of the unit is available.

General information regarding performance and specifications for the equipment may be obtained from our Technical Literature, and / or project specific documentation.

2.1 XBC Unit Code Description

1	2	-	3	-	4	5	-	7	-	8
XBC	75	-	H	-	L	ES	-	R	-	WP

- 1. Range: **XBOXER**
- 2. Unit Size: **75, 85**
- 3. Unit Layout: **H** = Horizontal
V = Vertical
- 4. Heating Type: **E** = Electric
L = LPHW
N = No Heating
- 5. Control Type: **BC** = Basic
ES = Ecosmart Classic
- 6. Unit Handing: **No Affix** = Left Hand Arrangement
R = Right Hand Arrangement
- 7. Unit Roof: **No Suffix** = Standard Unit (No Roof)
WP = Twin Pitched Roof (Factory Fitted)

2.2 Matched Attenuator Code Description

1	2	-	3	-	4	5	-	6
XBC	75	-	H	-	SIL	900	-	WP

- 1. Range: **XBOXER**
- 2. Unit Size: **75, 85**
- 3. Unit Layout: **H** = Horizontal
V = Vertical
- 4. Ancillary Type: **SIL** = Attenuator
- 5. Attenuator Length: **900** = 900mm
- 6. Unit Roof: **No Suffix** = Standard Unit (No Roof)
WP = Twin Pitched Roof (Factory Fitted)

3.0 DELIVERY

3.1 Receiving Equipment

All equipment is inspected prior to despatch and leaves the factory in good condition. Upon receipt of the equipment an inspection should be made and any damage indicated on the delivery note.

Particulars of damage and/or incomplete delivery should be endorsed by the driver delivering the goods before offloading by the purchaser. No responsibility will be accepted for damage sustained during the offloading from the vehicle or on the site thereafter. All claims for damage and/or incomplete delivery must be reported to Nuair within two days of receipt of the equipment.

3.2 Vehicle Offloading / Equipment Handling

XBC unit sections will be delivered to site in one section. The weight of the unit modules and palletised items is displayed on the unit rating plate or on the packaging. Some of the modules have an 'uneven' weight distribution, and this will be indicated by labelling where appropriate. Ensure that lifting and handling equipment is adequately rated. Offloading and positioning of the equipment is the responsibility of the purchaser.

Spreaders should be used when lifting with slings to avoid damage to the casings. Care must be taken to ensure that slings are correctly positioned to avoid crushing and twisting of the unit castings. Where channels and/or support frames are bolted to the underside of the unit casing, slings or fork-lift arms should be positioned to locate in the apertures in the channels. If Lifting Eyes have been supplied / fitted it is recommended that they are used.

CAUTION: The XBC75 & 85 fan units have an uneven weight distribution, please refer to the unit labelling before Lifting / offloading the unit.

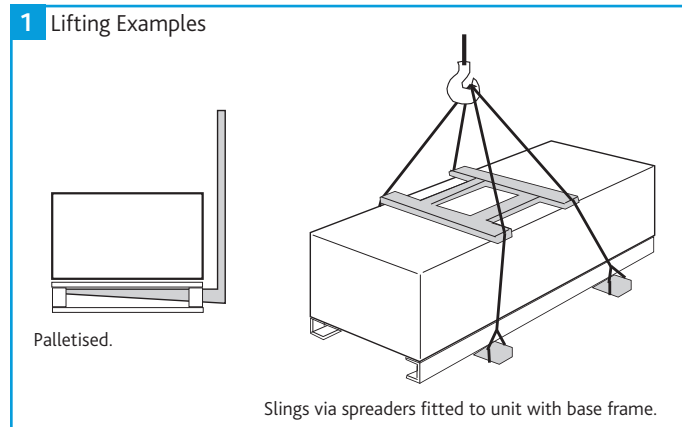

3.3 Storage

The equipment must be stored in a dry, internal location. Ductwork connection apertures shall be sealed against the ingress of dust, water and vermin. If the storage period is to exceed two months, contact Nuair for guidance on the appropriate "mothballing" procedures. Do not stack units, modules or components.

4.0 DIMENSIONS & WEIGHTS

4.1 Horizontal Units (XBC75-H, XBC85-H)

The unit is designed for side access as standard and must be installed with a minimum of clearance of 650mm from a wall or barrier.

This will provide access to filters, coil, fan, heat exchanger, condensate tray and pump. All models: The weather roof is part of the unit code and is factory fitted only. Example: XBC85-V-LESWP. Note: Codes with 'R' i.e. (XBC75-G4B-HR) refer to right hand unit versions.

2 Horizontal Unit Dimensions (mm) and Weights (kg)

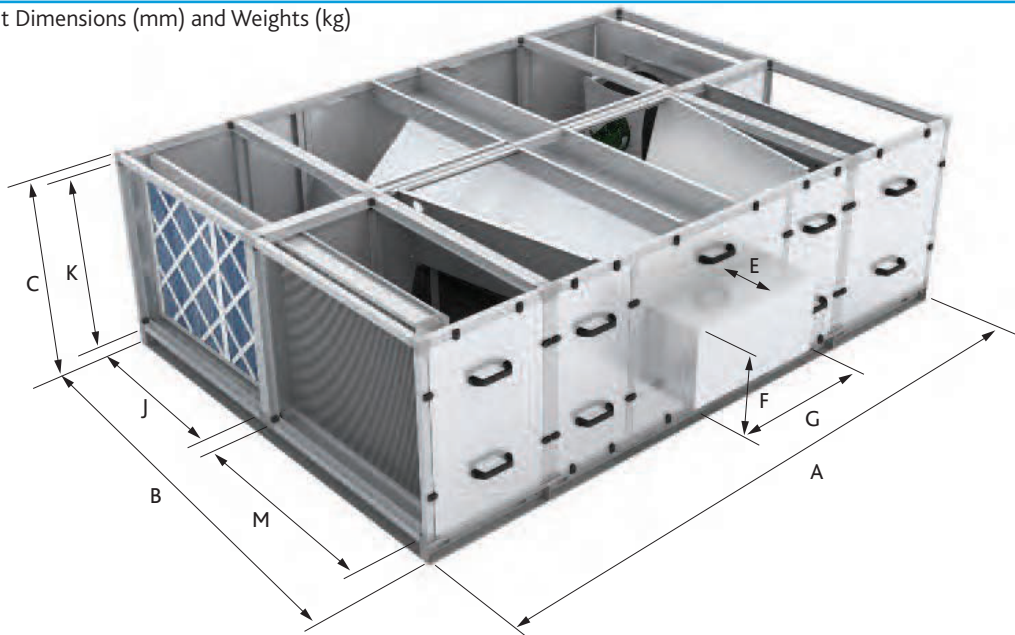

Unit Code	Unit Dimensions (mm)						Control Dimensions (mm)			Unit Weight (kg)	Packed Weight (kg)
	A	B	C	J	K	M	E	F	G		
XBC75-H-***	2800	2126	876*	940	740	940	250	730	800	720	902
XBC85-H-***	2800	2126	876*	940	740	940	250	730	800	835	942

*Includes unit and 76mm high base frame.

4.2 Horizontal Unit (XBC75-H, XBC85-H) Ancillaries

3 Horizontal Unit Ancillary References

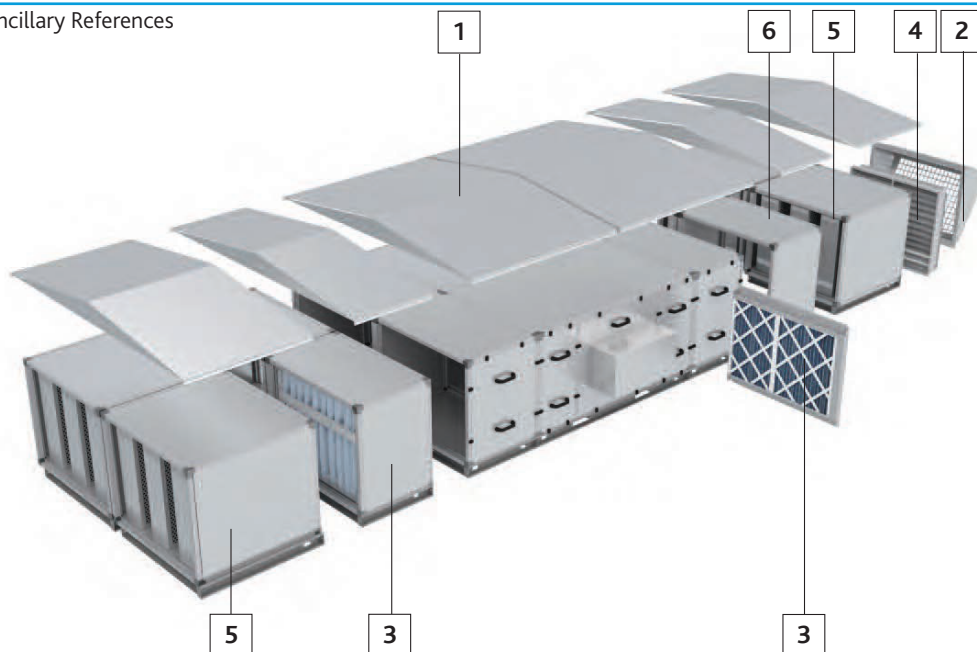

4.3.1 Units With Weather Kits

Ref. No.	XBC Unit Code	Description	Dimensions (mm)			Weight (kg)
			Width	Height	Length	
1	XBC75-H-***WP	Horizontal XBC75 Unit With Twin Pitched Roof	2000	1001	2800	720
1	XBC75-H-***-R-WP	Right Handed Horizontal XBC75 Unit With Twin Pitched Roof	2000	1001	2800	720
1	XBC85-H-***WP	Horizontal XBC85 Unit With Twin Pitched Roof	2000	1001	2800	835
1	XBC85-H-***-R-WP	Right Handed Horizontal XBC85 Unit With Twin Pitched Roof	2000	1001	2800	835

4.3.2 Weather Terminals

Ref. No.	XBC Ancillary Code	Description	Dimensions (mm)			Weight (kg)
			Width	Height	Length	
2	XBC75-H-RT	Weather Terminal For Horizontal XBC75 Units	940	740	700	8
2	XBC85-H-RT	Weather Terminal For Horizontal XBC85 Units	940	740	700	8

4.3.3 Filter Module Options

Ref. No.	XBC Ancillary Code	Description	Dimensions (mm)			Weight (kg)
			Width	Height	Length	
3	XBC75-F7B/G4P-H	F7 Bag / G4 Panel For Horizontal XBC75 Units	2000	876	600	115
3	XBC85-F7B/G4P-H	F7 Bag / G4 Panel For Horizontal XBC85 Units	2000	876	600	115
3	XBC75-F7B/G4P-HR	F7 Bag / G4 Panel For Right Handed Horizontal XBC75 Units	2000	876	600	115
3	XBC85-F7B/G4P-HR	F7 Bag / G4 Panel For Right Handed Horizontal XBC85 Units	2000	876	600	115
3	XBC75-G4B-H	G4 Bag For Horizontal XBC75 Units	2000	1001	600	115
3	XBC85-G4B-H	G4 Bag For Horizontal XBC95 Units	2000	1001	600	115
3	XBC75-G4B-HR	G4 Bag For Right Handed Horizontal XBC75 Units	2000	1001	600	115
3	XBC85-G4B-HR	G4 Bag For Right Handed Horizontal XBC85 Units	2000	1001	600	115
3	XBC75-F7B/G4P-HWP	F7 Bag / G4 Panel With Twin Pitched Roof For Horizontal XBC75 Units	2000	876	600	117
3	XBC85-F7B/G4P-HWP	F7 Bag / G4 Panel With Twin Pitched Roof For Horizontal XBC85 Units	2000	876	600	117
3	XBC75-F7B/G4P-HRWP	F7 Bag / G4 Panel With Twin Pitched Roof For Right Handed Horizontal XBC75 Units	2000	876	600	117
3	XBC85-F7B/G4P-HRWP	F7 Bag / G4 Panel With Twin Pitched Roof For Right Handed Horizontal XBC85 Units	2000	876	600	117
3	XBC75-G4B-HWP	G4 Bag with weather roof For Horizontal XBC75 Units	2000	1001	600	117
3	XBC85-G4B-HWP	G4 Bag with weather roof For Horizontal XBC85 Units	2000	1001	600	117
3	XBC75-G4B-HRWP	G4 Bag with weather roof For Right Handed Horizontal XBC75 Units	2000	1001	600	117
3	XBC85-G4B-HRWP	G4 Bag with weather roof For Right Handed Horizontal XBC75 Units	2000	1001	600	117

4.3.4 Dampers

Ref. No.	XBC Ancillary Code	Description	Dimensions (mm)			Weight (kg)
			Width	Height	Length	
4	XBC75-H-MD230V	230V Motorised dampers for Horizontal XBC75 Ecosmart model (ES) Units	620	560	165	14
4	XBC85-H-MD230V	230V Motorised dampers for Horizontal XBC85 Ecosmart model (ES) Units	840	700	165	25
4	XBC75-H-MD-NC	Damper no actuator with extended spindle for Horizontal XBC75 Basic Control (BC) Units	620	560	165	18
4	XBC85-H-MD-NC	Damper no actuator with extended spindle for Horizontal XBC85 Basic Control (BC) Units	840	700	165	29

4.3.5 Matching Attenuator Pairs (Side By Side, Supplied As One Piece)

Ref. No.	XBC Ancillary Code	Description	Dimensions (mm)			Weight (kg)
			Width	Height	Length	
5	XBC75-H-SIL900	Side by side silencer with base frame for Horizontal XBC75 Units	2000	876	900	225
5	XBC85-H-SIL900	Side by side silencer with base frame for Horizontal XBC85 Units	2000	876	900	225
5	XBC75-H-SIL900-WP	Side by side silencer with base frame and weather roof for Horizontal XBC75 Units	2000	1001	900	250
5	XBC85-H-SIL900-WP	Side by side silencer with base frame and weather roof for Horizontal XBC85 Units	2000	1001	900	250

4.3.6 Frost Coils (Side By Side, Supplied As One Piece)

Ref. No.	XBC Ancillary Code	Description	Dimensions (mm)			Weight (kg)
			Width	Height	Length	
5	XBC75-FCL-LNC-H	LPHW side by side module with base frame for basic control units (BC)	2000	876	600	113
5	XBC85-FCL-LNC-H	LPHW side by side module with base frame for basic control units (BC)	2000	876	600	113
5	XBC75-FCL-LES-H	LPHW side by side module with base frame for Ecosmart control units (ES)	2000	876	600	155
5	XBC85-FCL-LES-H	LPHW side by side module with base frame for Ecosmart control units (ES)	2000	876	600	155
5	XBC75-FCE-LNC-H	Electric side by side module with base frame for basic control units (BC)	2000	876	600	113
5	XBC85-FCE-LNC-H	Electric side by side module with base frame for basic control units (BC)	2000	876	600	113
5	XBC75-FCE-LES-H	Electric side by side module with base frame for Ecosmart control units (ES)	2000	876	600	121
5	XBC85-FCE-LES-H	Electric side by side module with base frame for Ecosmart control units (ES)	2000	876	600	121

4.4 Vertical Units (XBC75-V, XBC85-V)

The unit is designed for side access as standard and must be installed with a minimum of clearance of 650mm from a wall or barrier.

This will provide access to filters, coil, fan, heat exchanger, condensate tray and pump. All models: The weather roof is part of the unit code and is factory fitted only. Example: XBC85-V-LATWP. Note: Codes with 'R' i.e. (XBC75-G4B-HR) refer to right hand unit versions.

4 Vertical Unit Dimensions (mm) and Weights (kg)

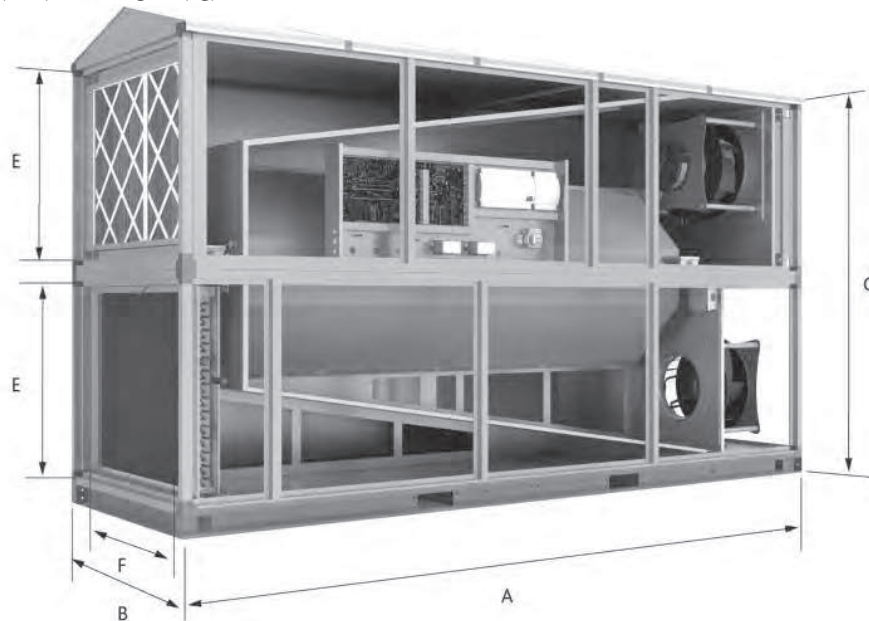

Unit Code	Unit Dimensions (mm)					Control Dimensions (mm)			Unit Weights (kg)	Packed Weights (kg)
	A	B	C	J	F	H	W	D		
XBC75-H-***	2500	954	1416	610	894	60	954	2500	630	730
XBC85-H-***	3000	1000	1676	940	740	65	1000	3000	780	880

*Includes unit and 76mm high base frame.

4.5 Vertical Units (XBC75-V, XBC85-V) Ancillaries

5 Vertical Unit Ancillary References

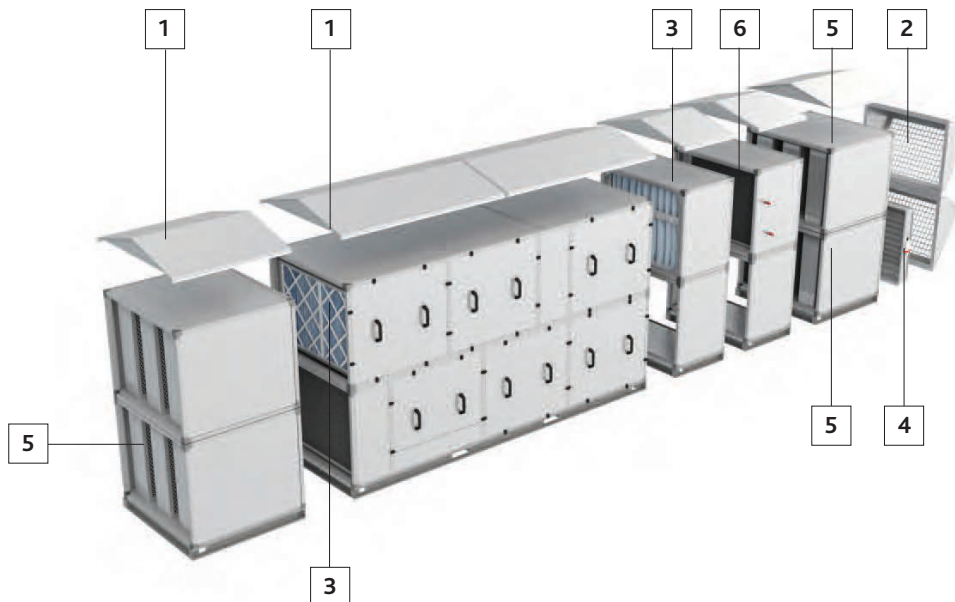

4.5.1 Unit With Weather Kits

Ref. No.	XBC Unit Code	Description	Dimensions (mm)			Weight (kg)
			Width	Height	Length	
1	XBC75-V-***WP	Vertical XBC75 Unit With Twin Pitched Roof	954	1476	2500	630
1	XBC75-V-***-RWP	Right Handed Vertical XBC75 Unit With Twin Pitched Roof	954	1476	2500	630
1	XBC85-V-***WP	Vertical XBC85 Unit With Twin Pitched Roof	1000	1741	3000	780
1	XBC85-V-***-RWP	Right Handed Vertical XBC85 Unit With Twin Pitched Roof	1000	1741	3000	780

4.5.2 Weather Terminals

Ref. No.	XBC Ancillary Code	Description	Dimensions (mm)			Weight (kg)
			Width	Height	Length	
2	XBC75-RT	Weather Terminal For Vertical XBC75 Units	842	570	610	8
2	XBC85-RT	Weather Terminal For Vertical XBC85 Units	940	740	700	10

4.5.3 Filter Module Options

Ref. No.	XBC Ancillary Code	Description	Dimensions (mm)			Weight (kg)
			Width	Height	Length	
3	XBC75-F7B/G4P	F7 Bag / G4 Panel For Vertical XBC75 Units	954	1416	600	90
3	XBC85-F7B/G4P	F7 Bag / G4 Panel For Vertical XBC85 Units	1000	1676	600	105
3	XBC75-F7B/G4P-R	F7 Bag / G4 Panel For Right Handed Vertical XBC75 Units	954	1416	600	90
3	XBC85-F7B/G4P-R	F7 Bag / G4 Panel For Right Handed Vertical XBC85 Units	1000	1676	600	105
3	XBC75-G4B	G4 Bag For Vertical XBC75 Units	954	1416	600	90
3	XBC85-G4B	G4 Bag For Vertical XBC95 Units	1000	1676	600	105
3	XBC75-G4B-R	G4 Bag For Right Handed Vertical XBC75 Units	954	1416	600	90
3	XBC85-G4B-R	G4 Bag For Right Handed Vertical XBC85 Units	1000	1676	600	105
3	XBC75-F7B/G4P-WP	F7 Bag / G4 Panel With Twin Pitched Roof For Vertical XBC75 Units	954	1476	600	92
3	XBC85-F7B/G4P-WP	F7 Bag / G4 Panel With Twin Pitched Roof For Vertical XBC85 Units	1000	1741	600	107
3	XBC75-F7B/G4P-RWP	F7 Bag / G4 Panel With Twin Pitched Roof For Right Handed Vertical XBC75 Units	954	1476	600	92
3	XBC85-F7B/G4P-RWP	F7 Bag / G4 Panel With Twin Pitched Roof For Right Handed Vertical XBC85 Units	1000	1741	600	107
3	XBC75-G4B-WP	G4 Bag with weather roof For Vertical XBC75 Units	954	1476	600	92
3	XBC85-G4B-WP	G4 Bag with weather roof For Vertical XBC85 Units	1000	1741	600	107
3	XBC75-G4B-RWP	G4 Bag with weather roof For Right Handed Vertical XBC75 Units	954	1476	600	92
3	XBC85-G4B-RWP	G4 Bag with weather roof For Right Handed Vertical XBC85 Units	1000	1741	600	107

4.5.4 Dampers

Ref. No.	XBC Ancillary Code	Description	Dimensions (mm)			Weight (kg)
			Width	Height	Length	
4	XBC75-V-MD230V	230V Motorised dampers for Vertical XBC75 Ecosmart model (ES) Units	620	560	165	14
4	XBC85-V-MD230V	230V Motorised dampers for Vertical XBC85 Ecosmart model (ES) Units	840	700	165	20
4	XBC75-V-MD-NC	Damper no actuator with extended spindle for Vertical XBC75 Units	620	560	165	14
4	XBC85-V-MD-NC	Damper no actuator with extended spindle for Vertical XBC85 Units	840	700	165	20

4.5.5 Matching Attenuator Pairs (Double Deck, Supplied As One Piece)

Ref. No.	XBC Ancillary Code	Description	Dimensions (mm)			Weight (kg)
			Width	Height	Length	
5	XBC75-V-SIL900	Double deck silencer with base frame for Horizontal XBC75 Units	954	1416	900	180
5	XBC85-V-SIL900	Double deck silencer with base frame for Horizontal XBC85 Units	1000	1676	900	200
5	XBC75-V-SIL900-WP	Double deck silencer with base frame and weather roof for Horizontal XBC75 Units	954	1476	900	185
5	XBC85-V-SIL900-WP	Double deck silencer with base frame and weather roof for Horizontal XBC85 Units	1000	1741	900	205

4.5.6 Frost Coils (Double Deck, Supplied As One Piece)

Ref. No.	XBC Ancillary Code	Description	Dimensions (mm)			Weight (kg)
			Width	Height	Length	
6	XBC75-FCL-LNC-V	LPHW double deck module with base frame for basic control units (BC)	954	1416	600	115
6	XBC85-FCL-LNC-V	LPHW double deck module with base frame for basic control units (BC)	1000	1676	600	120
6	XBC75-FCL-LES-V	LPHW double deck module with base frame for Ecosmart control units (ES)	954	1416	600	115
6	XBC85-FCL-LES-V	LPHW double deck module with base frame for Ecosmart control units (ES)	1000	1676	600	120
6	XBC75-FCE-LNC-V	Electric double deck module with base frame for basic control units (BC)	954	1416	600	100
6	XBC85-FCE-LNC-V	Electric double deck module with base frame for basic control units (BC)	1000	1676	600	105
6	XBC75-FCE-LES-V	Electric double deck module with base frame for Ecosmart control units (ES)	954	1416	600	100
6	XBC85-FCE-LES-V	Electric double deck module with base frame for Ecosmart control units (ES)	1000	1676	600	105

5.0 ACCESS CONCEPTS

In this product range, several unique concepts have been implemented with a view to simplifying the installation design.

Isolate before removing any panels

- The unit must be installed with at least 650mm clearance from a wall / barrier. With this absolute minimum clearance, the unit may be connected to the power supply and control connection. 1000mm clearance is required to remove the LPHW coil and electric heater.
- With this clearance, unit filters may be changed, and the fans coils, heat exchanger and condensate tray may be inspected and cleaned if necessary.
- The LPHW and Electrical heater settings, coil bleed and drain, and all other control adjustments are similarly accessible.
- Side access, where possible, is preferred in all cases in terms of safe working access to the equipment under the CDM regulations.
- Note however, that access in the situation is difficult and additional time should be allocated. For convenience it is preferred that wherever possible, this minimum access provision is not adopted, and it is recommended that a minimum of around 600mm clearance (as stated in ADF 2010) is allowed.
- Where these arrangements are not suitable, the Consultant's and Contractor's project specific requirements will always be accommodated where possible.

5.1 Horizontal Units (e.g. XBC75-H, XBC85-H)

6 Horizontal Unit Access

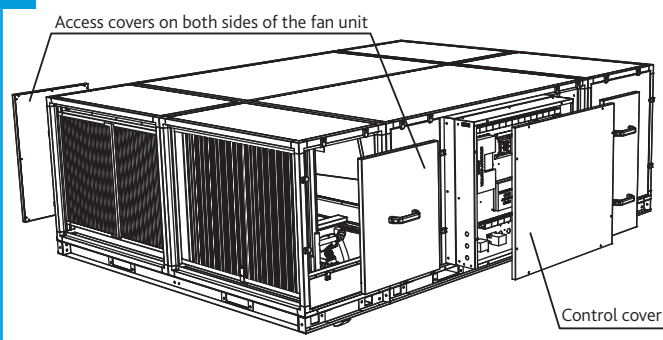

7 Horizontal Unit Overview With Lid Removed Showing Air Paths

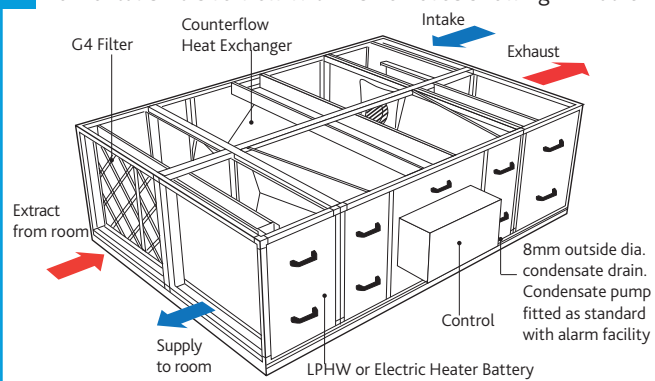

5.2 Vertical Units (e.g. XBC75-V, XBC85-V)

8 Vertical Unit Access

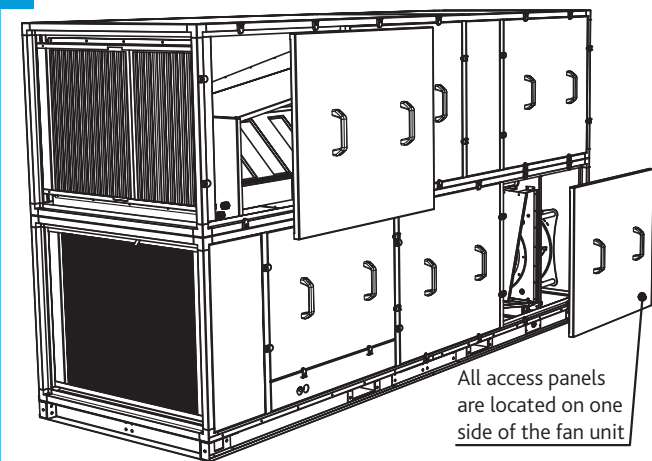

Note: Unit must be isolated before panels are removed.

9 Vertical Unit Overview With Lid Removed Showing Air Paths

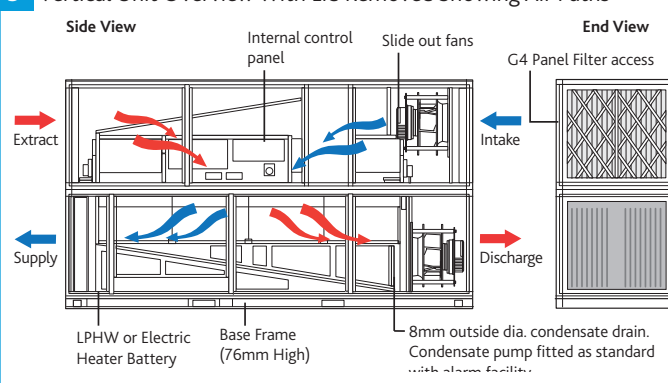

6.0 MECHANICAL INSTALLATION

Installation must be completed by competent persons, in accordance with good industry practice and should conform to all governing and statutory bodies i.e. IEE, CIBSE, etc.

The unit will be labelled with the direction of air flow. The direction convention must be observed during installation.

The unit may only be operated in its intended horizontal installation plane. The unit MUST be fully levelled during installation (this is essential to ensure that condensate drains correctly).

The units are heavy, and should be mounted using suitable methods of support. The supporting structure must be assessed for structural suitability.

If these units are being fitted into a ceiling void a suitable support structure must be provided under each unit, the base frame provided is **NOT suitable** for this purpose.

LPHW Coils, if fitted, are tested during manufacture to 16 Bar (using dry compressed air). Coil and valve assemblies are similarly tested to 10 Bar. Operation of standard equipment is rated at PN6, if the intended system requires higher operating pressures; please contact the Nuair Technical department for advice.

Electrical connections to the unit shall be made in accordance with the appropriate product; and installation wiring diagrams, and shall use appropriately sized and rated cables.

Only the prepared apertures in the unit casing may be used for cable entry. Do not drill or cut the unit casing for this purpose. Cable access points are provided at the ends of the control enclosure.

If the control is rotated to aid connection of cables, please ensure that sufficient flexibility is provided in the final connection run.

To avoid conflict with the unit access panels, it is recommended that electrical and plumbing service connections to the unit are run at 90 degrees to the main air flow axis.

Control circuit connections must be segregated (i.e. routed separately) from power connections.

The unit rating label shows the maximum electrical load of the equipment. Connections to the unit may include single phase supply connections, and a variety of control circuits.

Only the prepared apertures in the unit casing may be used for cable entry. Do not drill or cut the unit casing for this purpose.

The equipment must be earthed and earth-bonded. Means of local isolation for maintenance purposes are generally required (by others). Ensure that all mains connections are isolated.

Heat recovery components and modules that incorporate cooling coils may produce condensation during use. An insulated drip tray and condensate pump is provided. The drain connection must be connected to a suitable drainage point (Figures 10 & 11).

6.1 Condensate Pump

The condensate pump incorporates an alarm function. If the water level in the condensate tray exceeds a maximum level (for example, as a result of the discharge tube becoming blocked or frozen), the alarm contact will open. This contact is internally connected to the heat exchanger bypass actuator, and the unit will automatically be placed into bypass mode, preventing further condensate production. Unit operation will otherwise be unaffected.

Maximum flow rate = 12 l/h

Maximum head = 20m Vertical, 100m Horizontal

Pipe Connection size (Condensate) XBOXER XBC = 8 mm

6.2 Pre-Commissioning

Not all of the components listed here are necessarily included with the equipment supplied.

10 Customer Connections (Control Side of Horizontal Unit)

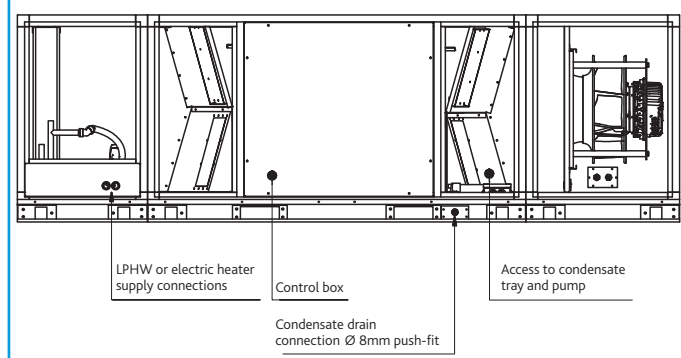

6.2.1 Filters

Remove filter access panels (observe and note airflow direction labels), inspect filters for contamination with construction debris, replace as necessary. Replace access panels.

Filter pressure drops will depend on actual flow rate and condition. Observe and record filter pressure drops after performance commissioning. Typically, filter "dirty" condition occurs when the initial filter "clean" readings have been increased by 125Pa.

If filter manometers, pressure switches or indicators have been fitted, they should be set or adjusted to reflect the commissioned system operation.

11 Customer Connections (Control Side of Vertical Unit)

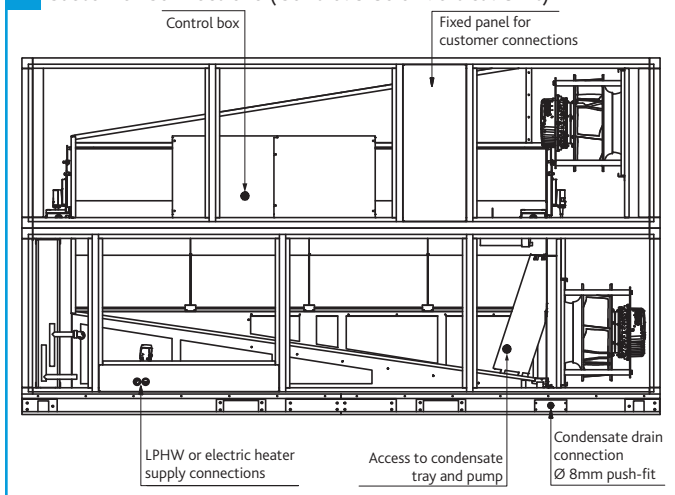

6.2.2 Heating Coils LPHW

Observe the Flow and Return connection labels on the unit. Drain and bleed valves are located on the coil. Other valves may be required in the system pipe-work depending on the installation (by others).

Where the wet system is at risk of frost damage, the addition of a proprietary anti-freeze solution to the water is recommended. Note that any frost protection offered by the unit's integral control system will not operate if the power supply to the unit is interrupted.

Ecosmart frost protection is activated on any Ecosmart unit fitted with LPHW heating, when the outlet air temperature is 4°C or below. The unit reacts by shutting down the fan to prevent a 'wind chill' effect reducing the temperature to a point whereby the coil could freeze and burst. The unit will also drive open the LPHW valve to a fully open position to allow full water flow through the coil and the main PCB will close the 'Heat demand' contacts. These contacts could be used to send a signal to activate the boiler and/or valve to open to provide heat if not already doing so.

Piped connections should be made to the unit using appropriate techniques, and all pipework must be independently supported. No hot work is permitted within one metre of the unit.

Ensure that installed pipework runs do not prevent or restrict access to the unit at any point.

The completed installation (including the connections within the unit, as these may be disturbed during installation) shall be pressure tested to the project engineer's specification (**This is a condition of the unit warranty**).

6.2.3 Electric Heaters

**Heater Capacity: XBC75 – 3ph, 12Kw
XBC85 – 3ph, 18Kw**

The Electric Heater requires a 3ph supply which is independent from the main unit supply. Connections to be made through the low level fixed panel. The Electric Heater may be withdrawn to allow access to the Heater Controller without the need for wiring to be disconnected (Ensure the mains supply is isolated before removing any access panels and any adjustments are made to the Heater Controller).

6.2.4 Fan Sections

Access to the fan section is via lift off panels. For non-Ecosmart units, wiring to the fan motor / unit terminal box should be mechanically protected and in made in accordance with the details on the motor name plate and diagram attached to the unit.

With the unit electrically isolated, rotate the fan impeller / drive manually, checking that it spins freely. **Check all fixings are secure.**

Units must not be operated without all access panels in place – damage to equipment or injury to personnel may result. Units must not be operated unless control interlocks are in place – damage to equipment may result.

Test run motor for condition and correct rotation. Check that the correct current overloads are fitted and that the current being drawn does not exceed the motor nameplate value. Excessive current normally indicates that the ductwork system resistance is different to design.

6.2.5 Motorised Dampers

If Nuair matched silencers (Horizontal: XBC75-H-SIL900, Vertical: XBC75-V-SIL900) are being fitted to the fan unit, the motorised damper (Horizontal: XBC75-H-MD230V, Vertical: XBC75-V-MD230V) needs to be fitted after the silencer.

If no weather cowls are present it is assumed that the intake and discharge on this unit are to be ducted away or have cowls provided by others. The ducting contractor is to ensure the ducting/cowl is fixed over the damper and fixed to the framework of the unit. This will ensure the actuator on the damper is protected from weather conditions. Access to the actuator via a ductwork access hatch is recommended (by others).

This ensures that breakout noise levels are kept to a minimum.

- Fully interlocking parallel blades, half inch diameter electroplated mild steel spindle.
- Nylatron bushes and external nylon/aluminium blade interconnection linkage.
- Fitted with drive open/drive close actuator complete with switch.
- Motorised damper wiring will require connection on site and possible extension of the cable looms.

12 Motorised Damper Actuator

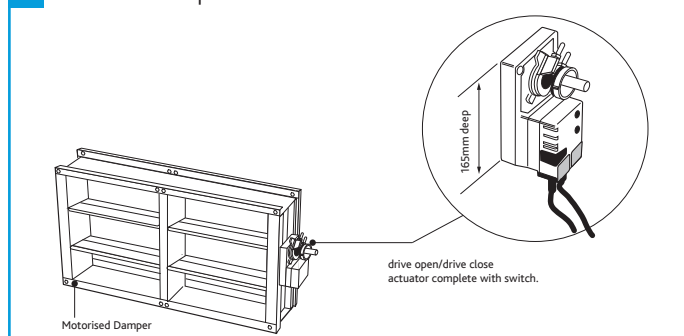

13 Motorised Damper Wiring

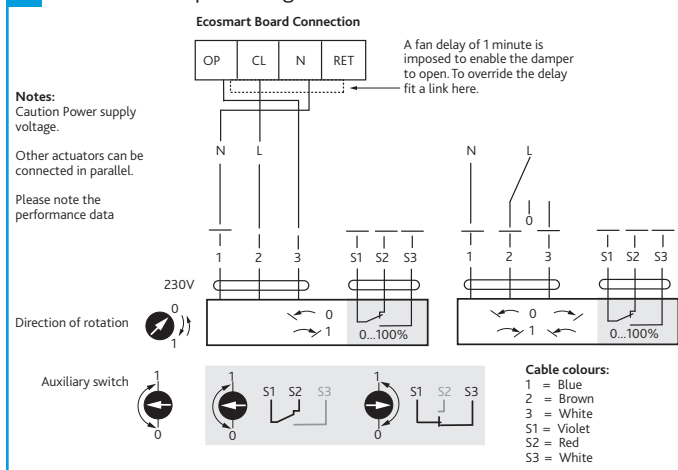

6.3 Constant Pressure Range (CP) - Controlling Static Pressure at Fan Inlet

Ecosmart constant pressure extract fans are supplied to control the static pressure at the fan inlet.

This set up is suitable for the majority of applications. When ancillaries with high pressure losses are fitted to the inlet side of the fan, the low pressure tapping must be moved from the fan chamber to a location upstream of the ancillaries, as shown below in Figure 14.

Failure to do this will result in excessive pressure being applied to the dampers at the rooms when the system is running in trickle mode.

14 Typical Constant Pressure Setup

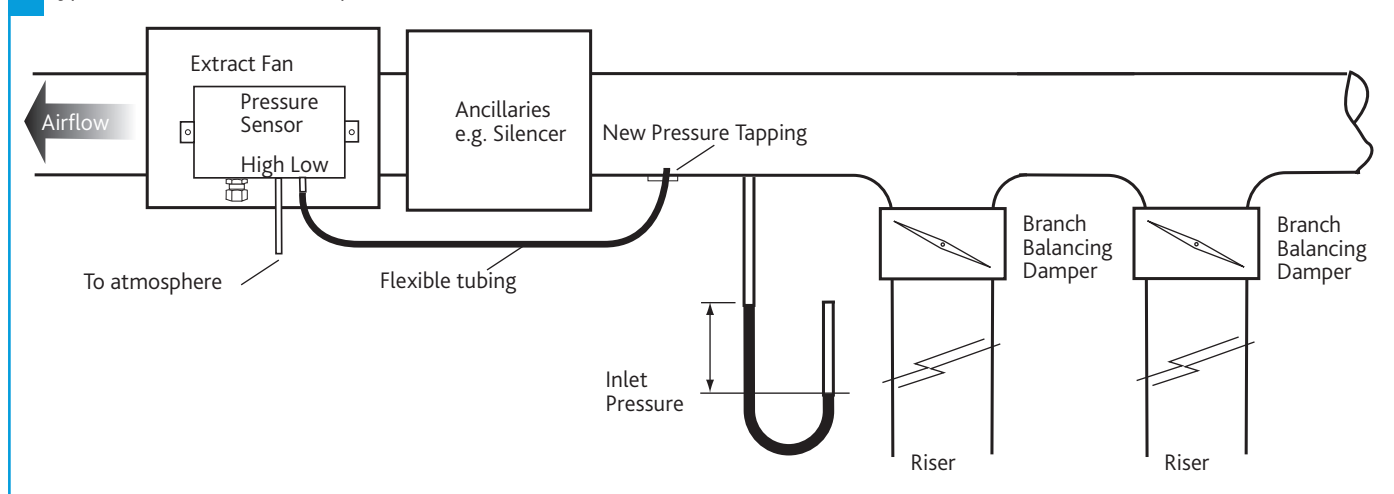

6.4 Filter Pressure Switch

XBC 75 & 85 units come with pre fitted pressure tapplings and tubing for use with the fitted dirty filter alarms on both the supply and extract air streams. The IP54 pressure switch is equipped with a red visual LED alarm which will illuminate when the pressure reading surpasses that set by the adjustable knob.

6.4.1 Setting Switch Pressure

Make certain that there is no voltage on the electrical connections before you carry out any setting on the pressure switch, there is the possibility of an electric shock if you accidentally touch live parts.

Nuair recommend the pressure switch be set to trigger when the filters experience a 125 Pa increase above the clean filter resistance for the largest commissioned airflow rate. Use the adjustment dial to set the pressure at which the switch will trip. When the pressure falls below this set value, the switch returns to its resting position.

6.4.2 Switch Wiring

The cable gland is designed for cables with alternative sheath diameters of 7 mm or 10 mm. Only use these sizes, otherwise the screw cable connection cannot seal adequately. The connections are intended for 6.3mm crimp-type sockets.

Remove switch cover. Wire the main unit to the terminal block within the switch as per the below wiring diagrams (Figure 15) ensuring the feed line is fused to suit Max 1.5A / 250 Vac. Refit switch cover.

15 Switch Wiring

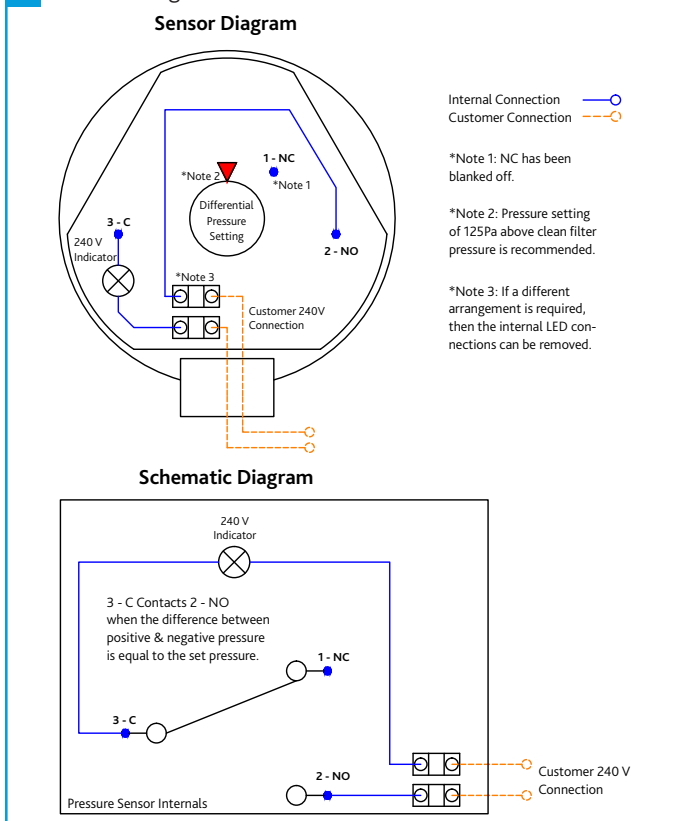

6.5 Hardware Positions

6.5.1 Key To Hardware Positions

- A. Supply Fan (Drive & Health)
- B. Supply Air Temperature Sensor
- C. Extract Air Temperature Sensor
- D. Thermal Trip (Electric Heater Only)
- E. LPHW Heater (LPHW Models Only)
- F. Bypass Damper Drive
- G. Condensate Pump Alarm
- H. Fresh Air Temperature
- I. Extract Fan (Drive & Health)

6.5.2 Horizontal Units

16 Horizontal Unit Hardware Positioning

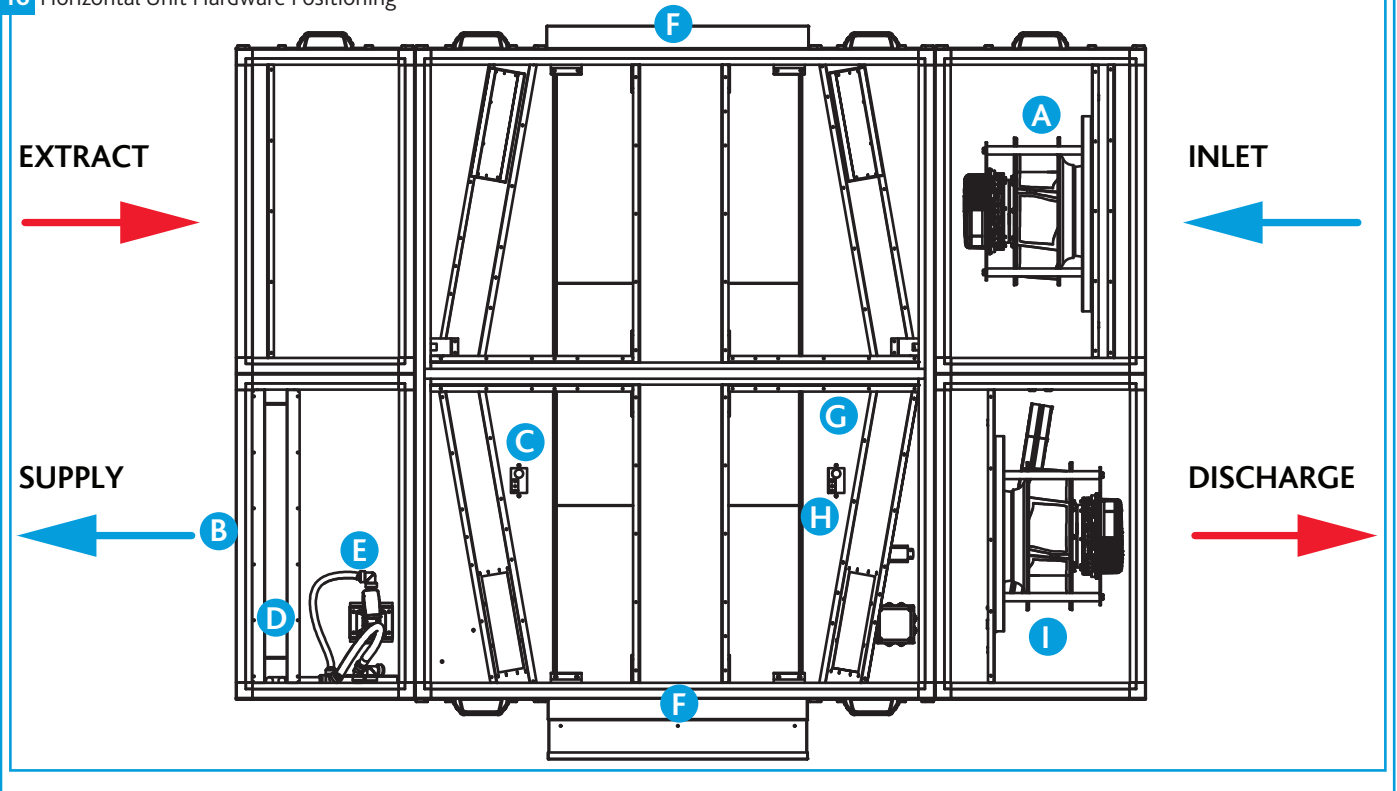

6.5.3 Vertical Units

17 Vertical Unit Hardware Positioning

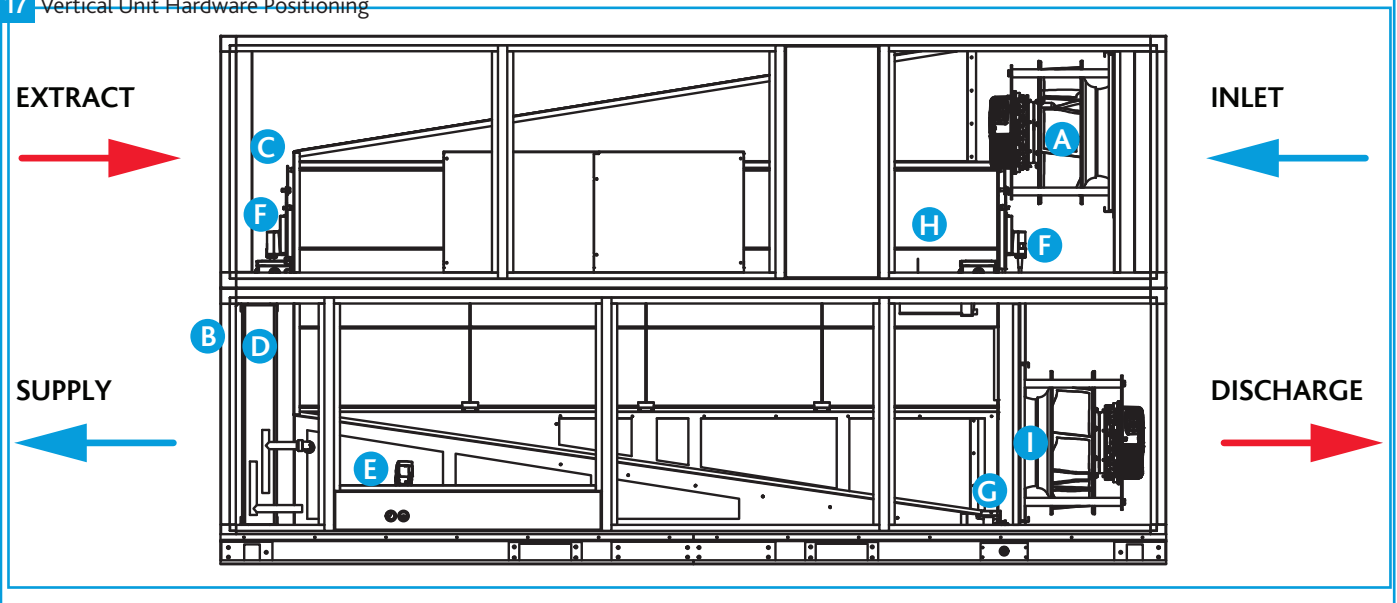

7.0 ELECTRICAL INSTALLATION

Before commencing work, make sure that the unit, switched live and Nuair control are electrically isolated from the mains supply.

All inter-connections between circuit boards, blowers and sensors are made at the factory. This diagram only shows the essential field wiring points for clarity.

7.1 Ecosmart Control (ES) Units

*Remove link wire if switched live signal, an enabler or BMS signal is connected.

†If a damper is not fitted, connect (Factory Fitted) a link wire from OP to RET. This will cancel the delay.

Independent speed control can be achieved by removing the net link connection between supply and extract control boards.

7.1.1 Volt Free Contacts

Volt free contacts are not fused. If these are used to power any external equipment, the installer must provide adequate fusing or other protections. These contacts are rated at 5 A resistive, 0.5 A inductive.

Run Connections - Contacts: closed when fan running.

Fault Connections - Contacts: closed when no fault, open when fault.

Heat Demand - Contacts: Closed when heating selected.

7.1.2 Wiring - ES Control, No Heating

18 Wiring - ES Control, No Heating

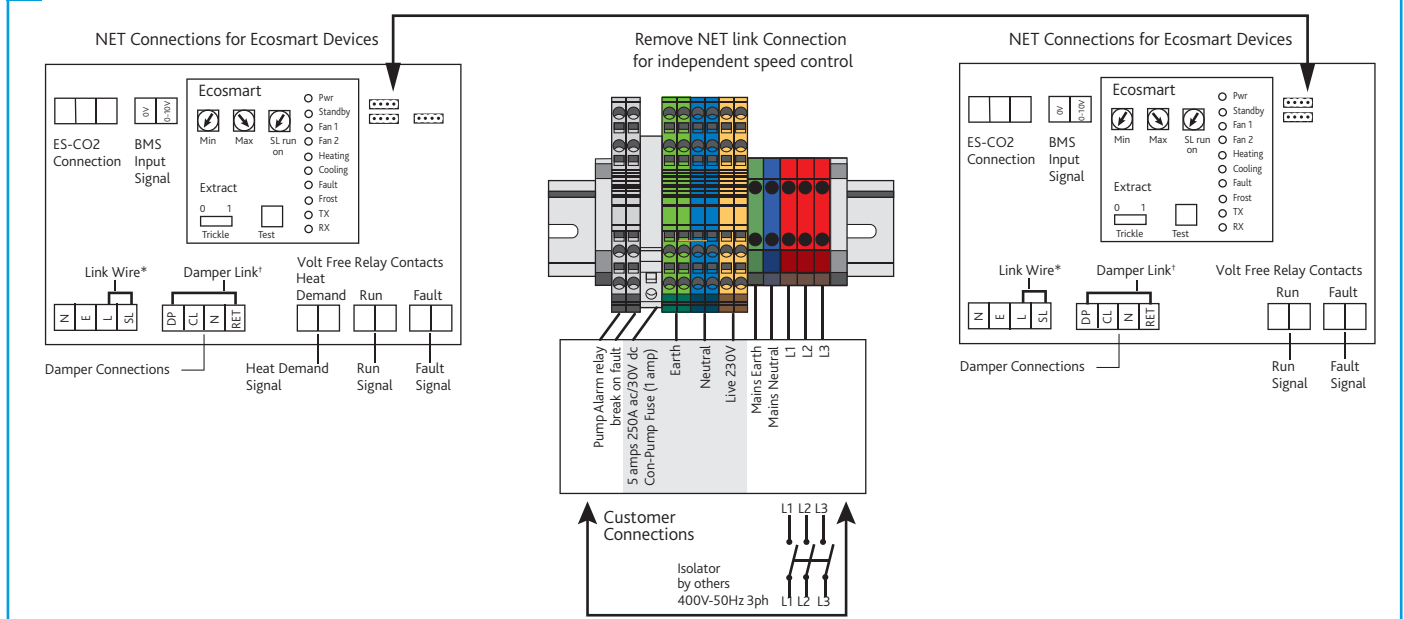

7.1.3 Wiring - ES Control, LPHW Heating

19 Wiring - ES Control, LPHW Heating

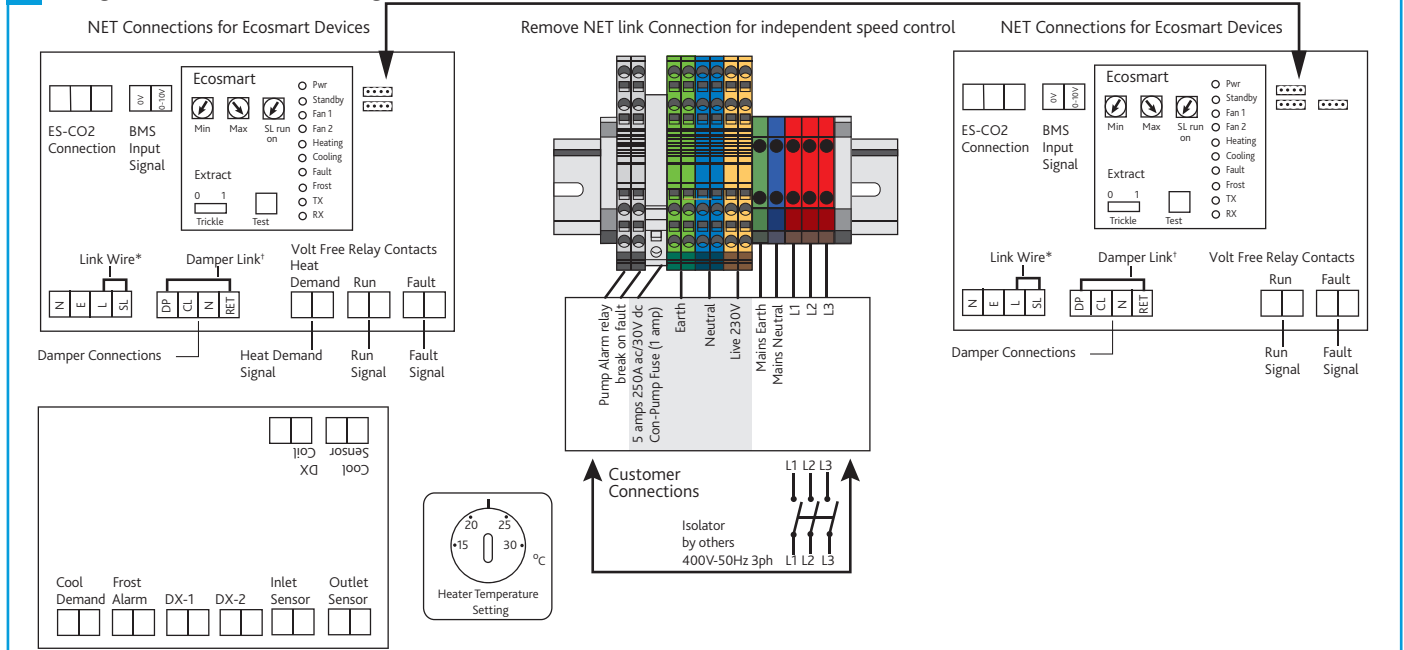

7.1.4 Wiring - ES Control, Electric Heating

20 Wiring - ES Control, Electric Heating

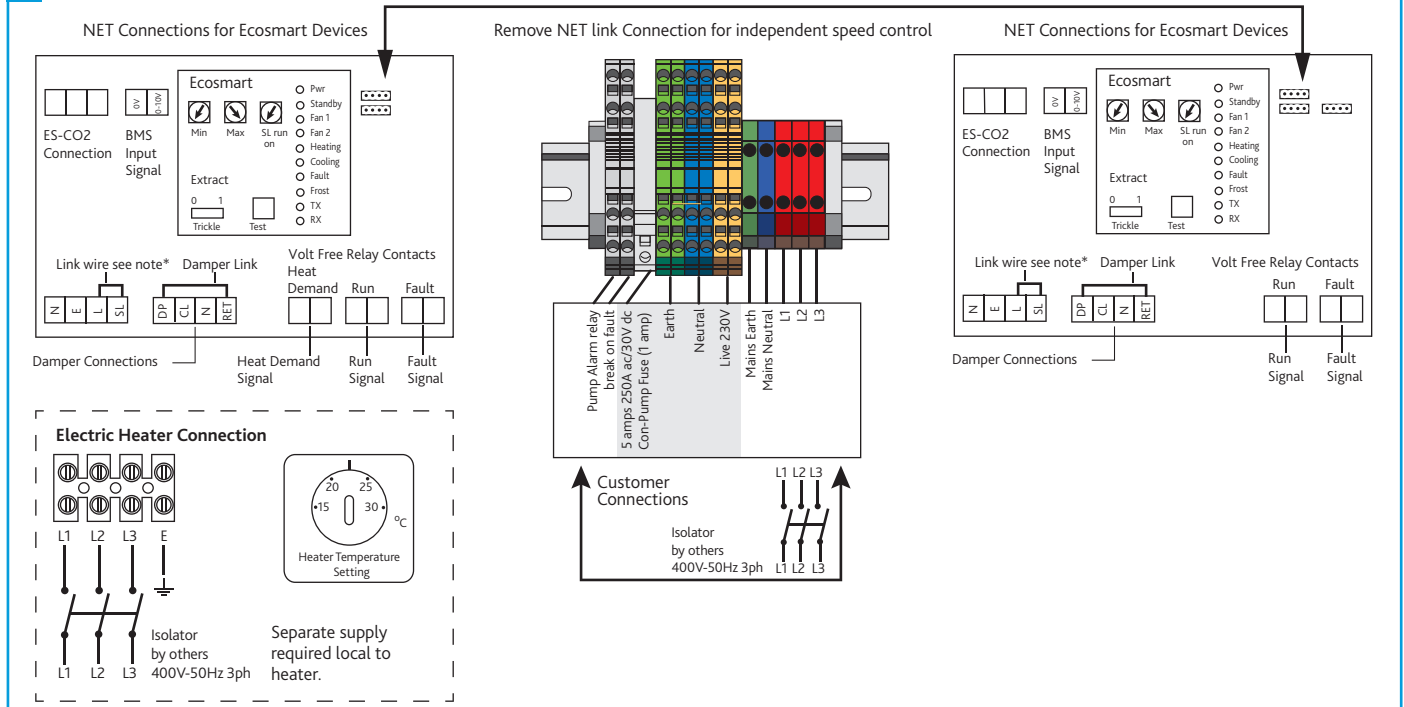

7.2 Basic Control (BC) Units

The Basic (BC) Control units described in this manual are supplied without any controls. It is the installer's responsibility to select and install suitable controller(s) and circuit(s) to produce the desired output from the units while remaining within the units safe performance envelope.

- Any electric heater must be connected to a suitable control circuit with adequate safety interlock to fan operation. Including an over temperature safety device rated at 80°C maximum. The fans should remain running for at least 4 minutes after the electric element is turned off to ensure the unit does not overheat.

- Do not wire power supply directly into the heating elements. A control circuit such as a thyristor controller must be used to regulate heater power.
- The alarm relay on condensate may require the use of a contactor if the host equipment supply is switched.
- Do not wire the power supply to motor via the motor alarm relay as terminals are only closed after the motor is energized.
- Any heating or cooling coils fitted are supplied without control valve and actuator.

The wiring illustrations below are for the fans, bypass damper and electric heater XBC units with basic control. All wiring is terminated in junction boxes fitted to the unit.

7.2.1 Wiring - BC Control

21 Wiring - BC Control

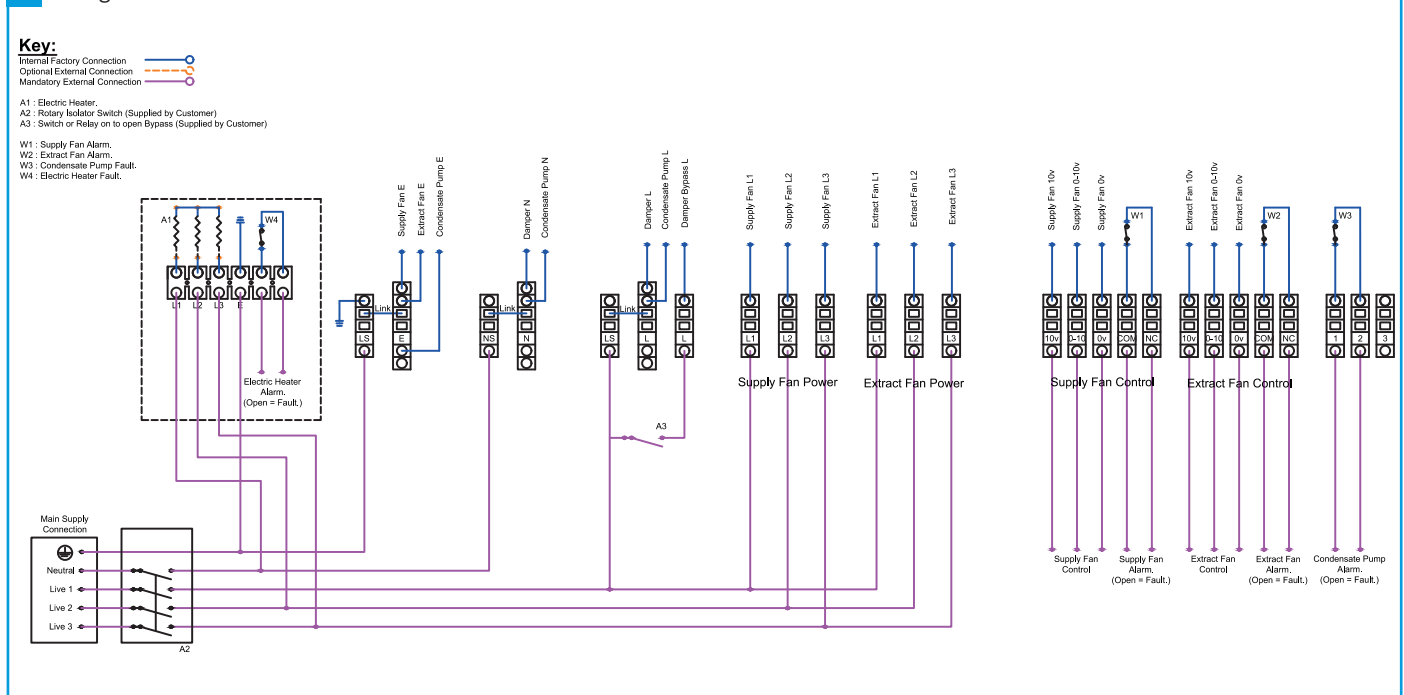

8.0 FROST COIL ANCILLARY (IF SUPPLIED)

All inter-connections between circuit boards, blowers and sensors are made at the factory. This diagram only shows the essential field wiring points for clarity.

8.1 LPHW Frost Coils

8.1.1 Wiring

The heater requires a 230V~50Hz single phase supply connection to power the thermostat and valve actuator. Remove the top cover from the terminal box by rotating the four fixing screws half a turn, revealing the terminal block marked LEN.

22 Wiring - LPHW Frost Coil Ancillary

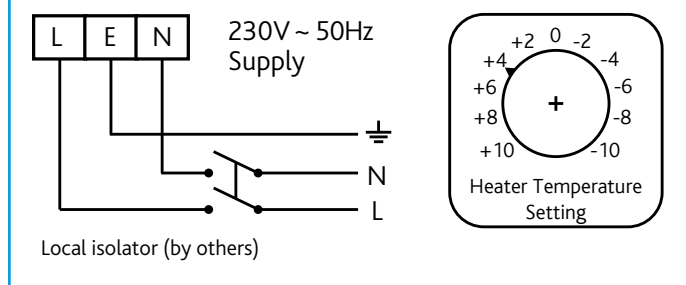

8.1.2 Setting 'Frost Condition' Temperature

The LPHW heater frost coil is only enabled if the frost stat reads a 'frost condition'. A 'frost condition' temperature adjustment dial is provided as part of the frost coil controls. The 'frost condition' temperature is easily adjustable from -10 to +10°C by inserting a small screwdriver into the adjuster aperture and rotating the spindle clockwise or anticlockwise. It is recommended that the 'frost condition' temperature is set at 4°C.

8.2 Electric Frost Coils

8.2.1 Wiring

The heater requires two connections; the SELV communications cable link up and the 400V~50Hz three phase supply connection to power the heater element. Remove the top cover from the terminal box by rotating the four fixing screws half a turn, revealing the terminal block.

The communications cable (supplied) can now be plugged into the socket marked Ecosmart NET inside the box. The other end of the SELV cable should be plugged into the connection box of the associated supply fan in the system.

23 Wiring - Electric Frost Coil Ancillary

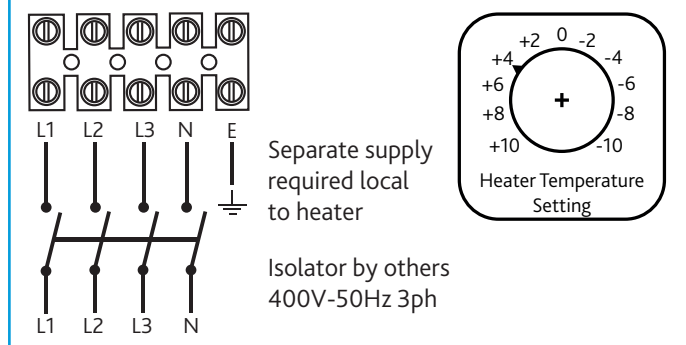

24 Wiring - Electric Frost Coil Ancillary SELV Communications Cable

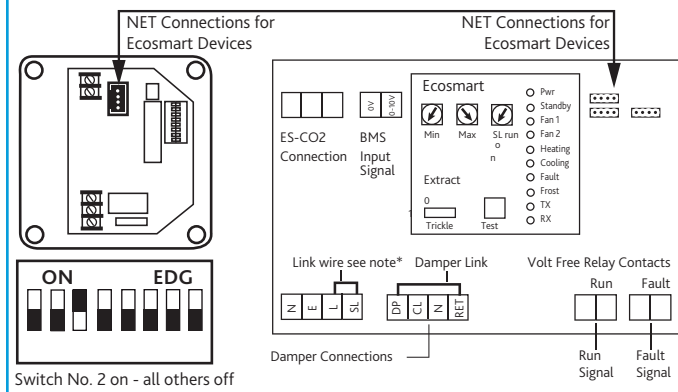

8.2.2 Setting 'Frost Condition' Temperature

The electric heater frost coil is only enabled if the frost stat reads a 'frost condition', the over-temperature cut-out is healthy AND a 24vac fan run signal is received from the main control panel. A 'frost condition' temperature adjustment dial is provided as part of the frost coil controls. The 'frost condition' temperature is easily adjustable from -10 to +10°C by inserting a small screwdriver into the adjuster aperture and rotating the spindle clockwise or anticlockwise. Once enabled the electric heater frost coil will provide its maximum heat output to achieve the 'frost condition' temperature set by the frost stat. It is recommended that the 'frost condition' temperature is set at 4°C.

9.0 CONTROLS

9.1 Test Button

The test button allows the individual blowers within the unit to be checked for its operation. If the fan is running already, press the button once to stop the fan, press again to switch on the fan. **The fan will return to normal operation after 30 seconds.**

9.2 LED Indication

PWR	GREEN: Power on & OK.
Standby	LED on when fan is not running.
Fan 1	GREEN: Fan 1 is running, RED: Fan 1 faulty.
Fan 2	GREEN: Fan 2 is running, RED: Fan 2 faulty.
Heating*	GREEN: Heating selected RED: Heating faulty
Cooling*	Not applicable. See note.
Fault	LED on when a fault is present on unit.
Frost*	Not applicable. See note.
TX	LED on when the controller is transmitting data.
RX	LED on when the controller is receiving data.

*The control panel is common to all the Ecosmart products and will have indicators for functions that are not available in this particular fan. However these indicators will not be illuminated.

9.3 BMS Inputs

The system's response to a 0-10V dc BMS signal is given in the following table. **The BMS signal will override any sensors and user control connected in the system. The voltage tolerance is +/- 125mV and is measured at the fans terminal.**

	Ventilation Mode	Cooling Mode*	Heating Mode*
Local Control	0.00	-	-
OFF/Trickle	0.25	-	-
Speed 1	0.50	0.75	1.00
Speed 2	1.50	1.75	2.00
Speed 3	2.50	2.75	3.00
Speed 4	3.50	3.75	4.00
Speed 5	4.50	4.75	5.00
Speed 6	5.50	5.75	6.00
Speed 7	6.50	6.75	7.00
Speed 8	7.50	7.75	8.00
Speed 9	8.50	8.75	9.00
Speed 10	9.50	9.75	10.00

9.4 Settings

9.4.1 Maximum Airflow

- Ensure the power supply is switched off and that a link wire is connected from the supply L to the SL terminal. Unplug all items connected to the 'Net' connectors.
- Switch on the power supply.
- Wait for the fan to complete its self-test operation.

Measure the airflow using standard commissioning instruments at a suitable point in the ductwork. If adjustment is required, rotate the pot marked 'MAX' to obtain the desired airflow.

9.4.2 Trickle Ventilation Facility

Slide the 'trickle' switch 0 = Off, 1 = On. With 'trickle' on and power to unit, the fan will run at minimum speed until the switch live signal activates it to boost.

9.4.3 Minimum Trickle Airflow (Nominal 40%)

- Repeat the same procedure as for maximum airflow above but without the link wire between supply L and SL terminal. Ensure the trickle switch is in the 'ON' position. Adjustment must be made on the pot marked 'Min'.
- The minimum setting (nominally 40%) must be below the maximum setting; otherwise minimum setting will be automatically set to be the same as the maximum.

9.4.4 Overrun Time

A switched live of 100-230V at terminal SL will activate the fan. When the switched live signal is removed the fan will overrun for period set by the dial 'SL run on' - adjust the desired overrun time by rotating clockwise.

9.4.5 'Air Off' Temperature

The adjustment knob is located in the control pack and must be set to the desired 'air off' temperature.

25 Control Board

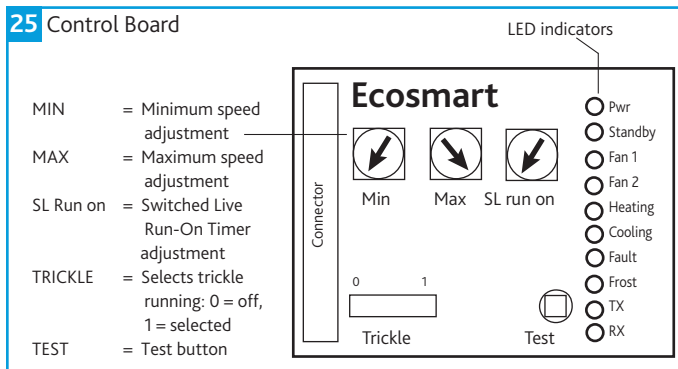

10.0 MAINTENANCE

It is important that maintenance checks are recorded and that the schedule is always adhered to, in all cases, the previous report should be referred to.

Before commencing work, make sure that the unit and Nuair control are electrically isolated from the mains supply. In some Ecosmart units and in some third party controls, variable speed drives (inverters) are used to provide fan speed control. After the fan is isolated, allow at least 5 minutes for the capacitors in the inverter to discharge before commencing any work on the unit.

10.1 Routine Maintenance

- Clean all areas of unit and treat any areas of corrosion.
- Check all access doors for leakage and if necessary locks should be adjusted and any replacement gasket materials should be replaced as required.
- Any drain trays should be cleaned and repaired if necessary.

10.2 Every 3 Months

- Check filters and change/clean if required, failure to do so may impair the performance and energy efficiency of this unit. Typically filters should be changed when the filters experience a 125 Pa increase above the clean filter resistance for the largest commissioned airflow rate.
- Ensure condensate drains are cleaned clear and that water can flow freely from unit.
- Check fin coil banks and heat exchangers. If necessary clean with a soft brush or vacuum. Check for signs of contamination.

10.3 Annually

- Thoroughly inspect the unit and its components for corrosion, acting immediately to treat/restore any damaged areas.
- All electrical terminals within the unit should be tightened.
- Check all earth connections.
- Check control dampers blades.
- Check operation of damper actuators and linkages and adjust as necessary.
- Coil faces should be inspected and any dust removed.
- Check any thermal wheel belt, motor, bearings, seals and if necessary clean with a soft brush or vacuum cleaner.

11.0 WARRANTY

A 5 year warranty on Ecosmart Control models, Basic Control models have a 2 year warranty. The warranty starts from the day of delivery and includes parts and labour for the first year. The remaining period covers replacement parts only.

This warranty is void if the equipment is modified without authorisation, is incorrectly applied, misused, disassembled, or not installed, commissioned and maintained in accordance with the details contained in this manual and general good practice.

The product warranty applies to the UK mainland and in accordance with Clause 14 of our Conditions of Sale. Customers purchasing from outside of the UK should contact Nuair International Sales office for further details.

Failure to maintain the unit as recommended will invalidate the warranty.

12.0 END-OF-LIFE AND RECYCLING

Where possible Nuair use components which can be largely recycled when the product reaches its end-of-life:

- Fans, motors, controls, actuators, cabling and other electrical components can be segregated into WEEE recycling streams.
- Sheet metal parts, aluminium extrusion, heating/cooling coils and other metallic items can be segregated and fully recycled.
- EPP, plastic ducting, nylon corner pieces, plastic heat exchangers, packaging material and other plastic components can be segregated into mixed plastic and widely recycled.
- Cardboard packaging, wood, used filters and other paper components can be largely recycled or fully processed in energy from waste centres.
- Remaining Items can be further segregated and processed in accordance with the zero waste hierarchy. Please call After Sales Support for further information on items not listed above.

Ensure that Nuair product is made safe from any electrical / water / refrigerant supplies before dismantling commences. This work should only be undertaken by a qualified person in accordance with local authority regulations and guidelines, taking into account all site based risks.

13.0 AFTER SALES AND REPLACEMENT PARTS

For technical assistance or further product information, including spare parts and replacement components, please contact the After Sales Department.

If ordering spares please quote the serial number of the unit together with the part number, if the part number is not known please give a full description of the part required. The serial number will be found on the identification plate attached to the unit casing.

Part Number	Description
XBC75-V-FILTERKIT	XBC75 Replacement G4 Panel Filters x4
776187	XBC75 Replacement Blower Assembly x1 (18kg)
XBC75-H-FILTERKIT	XBC85 Replacement G4 Panel Filters x4
776188	XBC85 Replacement Blower Assembly x1 (37kg)

13.1 Blower Replacement

Remove 4x fixings and slide blower out of unit to replace. **Caution: Blowers are heavy, see description above for weight.**

13.2 Filter Replacement

Remove retaining plate and slide filters out of unit to replace.

Telephone 02920 858 400
aftersales@nuair.co.uk

Technical or commercial considerations may, from time to time, make it necessary to alter the design, performance and dimensions of equipment and the right is reserved to make such changes without prior notice.

DECLARATION OF INCORPORATION AND INFORMATION FOR SAFE INSTALLATION, OPERATION AND MAINTENANCE

We declare that the machinery named below is intended to be assembled with other components to constitute a system of machinery. All parts except for moving parts requiring the correct installation of safety guards comply with the essential requirements of the Machinery Directive. The machinery shall not be put into service until the system has been declared to be in conformity with the provisions of the EC Machinery Directive.

Designation of machinery: XBOXER XBC Ecosmart (ES) and Basic Control models (BC)
Machinery Types: Supply & Extract fans with Heat Recovery
Relevant EC Council Directives: 2006/42/EC (Machinery Directive)
Applied Harmonised Standards: BS EN ISO 12100, BS EN ISO 13857 EN60204-1, BS EN ISO 9001
Applied National Standards: BS848 Parts 1, 2.2 and 5

Signature of manufacture representatives:

Name:	Position:	Date:
1) C. Biggs 	Technical Director	13. 05. 16.
2) A. Jones 	Manufacturing Director	13. 05. 16.

Note: All standards used were current and valid at the date of signature.

INFORMATION FOR SAFE INSTALLATION, OPERATION AND MAINTENANCE OF NUAIRE VENTILATION EQUIPMENT

To comply with EC Council Directives 2006/42/EC Machinery Directive and 2014/30/EU (EMC). To be read in conjunction with the relevant product documentation (see 2.1)

1.0 GENERAL

1.1 The equipment referred to in this Declaration of Incorporation is supplied by Nuairé to be assembled into a ventilation system which may or may not include additional components. The entire system must be considered for safety purposes and it is the responsibility of the installer to ensure that all of the equipment is installed in compliance with the manufacturers recommendations and with due regard to current legislation and codes of practice.

2.0 INFORMATION SUPPLIED WITH THE EQUIPMENT

2.1 Each item of equipment is supplied with a set of documentation which provides the information required for the safe installation and maintenance of the equipment. This may be in the form of a Data sheet and/or Installation and Maintenance instruction.
 2.2 Each unit has a rating plate attached to its outer casing. The rating plate provides essential data relating to the equipment such as serial number, unit code and electrical data. Any further data that may be required will be found in the documentation. If any item is unclear or more information is required, contact Nuairé.
 2.3 Where warning labels or notices are attached to the unit the instructions given must be adhered to.

3.0 TRANSPORTATION, HANDLING AND STORAGE

3.1 Care must be taken at all times to prevent damage to the equipment. Note that shock to the unit may result in the balance of the impeller being affected.
 3.2 When handling the equipment, care should be taken with corners and edges and that the weight distribution within the unit is considered. Lifting gear such as slings or ropes must be arranged so as not to bear on the casing.
 3.3 Equipment stored on site prior to installation should be protected from the weather and steps taken to prevent ingress of contaminants.

4.0 OPERATIONAL LIMITS

4.1 It is important that the specified operational limits for the equipment are adhered to e.g. operational air temperature, air borne contaminants and unit orientation.
 4.2 Where installation accessories are supplied with the specified equipment eg. wall mounting brackets. They are to be used to support the equipment only. Other system components must have separate provision for support. Flanges and connection spigots are provided for the purpose of joining to duct work systems. They must not be used to support the ductwork.
 4.4 **Local Environment - Humidity.** Ambient humidity (the humidity at the unit's installed location) shall be within the range: 10 to 95% (for controls, non-condensing). Air humidity (the humidity of the air passing through the unit) shall be within the range: 10 to 95% (for controls, non-condensing).

5.0 INSTALLATION REQUIREMENTS

In addition to the particular requirements given for the individual product, the following general requirements should be noted.
 5.1 Where access to any part of equipment which moves, or can become electrically live are not prevented by the equipment panels or by fixed installation detail (e.g. ducting), then guarding to the appropriate standard must be fitted.
 5.2 The electrical installation of the equipment must comply with the requirements of the relevant local electrical safety regulations.
 5.3 For EMC all control and sensor cables should not be placed within 50mm or on the same metal cable tray as 230V switched live, lighting or power cables and any cables not intended for use with this product.

6.0 COMMISSIONING REQUIREMENTS

6.1 General pre-commissioning checks relevant to safe operation consist of the following: Ensure that no foreign bodies are present within the fan or casing. Check electrical safety, e.g. Insulation and earthing. Check guarding of system. Check operation of Isolators/Controls. Check fastenings for security.
 6.2 Other commissioning requirements are given in the relevant product documentation.

7.0 OPERATIONAL REQUIREMENTS

7.1 Equipment access panels must be in place at all times during operation of the unit, and must be secured with the original fastenings.
 7.2 If failure of the equipment occurs or is suspected then it should be taken out of service until a competent person can effect repair or examination. (Note that certain ranges of equipment are designed to detect and compensate for fan failure).

8.0 MAINTENANCE REQUIREMENTS

8.1 Specific maintenance requirements are given in the relevant product documentation.
 8.2 It is important that the correct tools are used for the various tasks required.
 8.3 If the access panels are to be removed for any reason the electrical supply to the unit must be isolated.
 8.4 A minimum period of two minutes should be allowed after electrical disconnection before access panels are removed. This will allow the impeller to come to rest.
NB: Care should still be taken however since airflow generated at some other point in the system can cause the impeller to "windmill" even when power is not present.
 8.5 Care should be taken when removing and storing access panels in windy conditions.